

PLUSS™



Pluss Polymers is an offshoot of Manas, established to develop and market new technologies and products developed inhouse. Pluss Polymers was incorporated in 1993 to commercialise the technology for grafted modified polymers and alloys and blends. Backed by competent technical staff, laboratory facilities, a good library and technical database with a retrievable wealth of information marketed the OPTIM® brand of grafted polymers for the first time in India in 1996.

OPTIM® coupling agents and compatibilisers allow plastics manufacturers of world class quality products to *OPTIMise* their compound properties. The ADNYL® range of nylon alloys provide the user with extra tough nylon for increased strength.

Profiles and other rigid and flexible containers for thermal energy storage have also been introduced in India for the first time by Pluss Polymers.



Agricultural Wastes

+

Plastics Waste

+

Additives

=

Wood Plastics Composites.

Product

The composite may be described as wood filled plastics. The filler used is low price and scrap polyolefines are the matrix. A small percentage of modifiers is required to get the polyethylene or polypropylene to wet the highly polar Wood / Rice Husk / Agriculture waste.

The composite has the good properties of plastics such as water resistance, extrudability and formability. Presence of cellulosic filler keeps density of the composite low. It is paintable using regular enamel paints. Its scrap is recyclable

Likely Applications

Panels for interior partitions, Doors / Windows for outdoor exposure and industrial environment. Pallets for material handling. Pots for gardening / plantation (decorative), Table tops, moulded drawers, shelves etc. The product, being composed of more than 20% Agricultural waste, may not attract excise duty.

Raw Materials

1. Agricultural waste such as wood flour, saw dust, rice husk, cotton plant stalk powder, jute stalk powder, etc.
2. Polyethylene or polypropylene scrap in pellet form or as output from grinder or agglomerator.
3. A small proportion ~5% of a polymeric wetting agent and viscosity modifier.

Technology

Manas have carried out development work on their modified twin screw extruder with a separate machine for drying wood flour and compression moulding press to prove the technology. Commercially a modified Twin Screw Extruder and specially designed dies for profile extrusion will be required. Compounded granules can also be injection moulded.

Project Cost

- Machine Cost : For 150kg/hr output the main machine described above (for direct extrusion of products) shall cost approx. Rs 100 lakhs. For off line extrusion, machine cost will be of the order of Rs.60 lakhs.
- Technology Cost : A fixed technology price or an initial nominal payment followed by royalty based on commercial production.
- Other Costs : Usual associated with any project.

Extracts from Published Literature

“Veka Holdings, PA, USA is launching a composites decking system (fencing and railing products) based on vinyl and wood in spring 2001”.

“... Wood / Polyethylene decking is still under 5% of the North American deck market and potential for replacing wood is considerable ...”

*Michael Vatura, Trex, USA
Courtesy : Modern Plastics*

David Murdock, Davis Standards business area manager terms wood composites as “ the hottest extrusion market today bar none”, adding that eight Woodtruders were sold at the NPE Chicago 2000.

Mikron Industries, WA, USA views its patented wood composite “MikronWood” as promising for decking applications.

Crane Products, USA has developed 10' & 12' long profiles that are easy to install and use pre-notched nail holes and special channels to hide fasteners, providing a clean appearance.

National Institute of Industrial Research, New Delhi has come out with a detailed market survey and project report on production of wood flour.

In India, to enable growth of plastics / agricultural waste composites. The govt. has removed excise duties on such composites.

BMPTC, New Delhi has launched a ‘Performance Appraisal Certification Scheme’ to provide performance appraisal certificates for composite building materials to promote their use.

“.... Wood / Polyolefines composites are a marriage of materials that expand cost performance and raise potential for exterior profile extruders...”

*Al England, Executive V.P
Standard Corpn.,*

“In the US many compare the position of wood-plastics composites in profiles today to that of rigid vinyl in windows around 1980. These composites are now well positioned to replace lower cost and higher cost woods on the basis of cost performance.

Modern Plastics International

“ Wood flour is extensively being used for injection moulding and single screw extrusion. Thermoplastics resins using wood flour as filler include polyolefines, PVC, ABS and PS”.

American Wood Flour, USA

Commercial Applications Wood Flour/Agricultural Wastes - Plastics Composites

- 1. Thermoplastic Sheet Extrusion - upto 60% Fiber Loading
- 2. Thermoplastic Profiles - upto 70% Fiber Loading Pipe Extrusion
- 3. Rotational Moulded - upto 30% Fiber Loading Thermoplastics
- 4. Toys
- Others** - upto 60% Fiber Loading
- 5. Consumer products - Flower pots Lawn / Outdoor Furniture Tool Handles Storage Crates Extruded Door/ Window Frames Doors Windows Cosmetic Packaging Paint Roller/Brush Handles Housewares Chair Supports
- 6. Industrial Products - Material Handling Tote Bins Material Pallets Office Partitions
- 7. Roofing Sheets/Tiles - Door Panels Air Vents Under - Dash Parts Speaker Brackets

Base Resin	Filler Type %	Flex. Strength (Kg/cm ²)	Flex. Modulus (Kg/cm ²)	Impact StrengthNotched (J/m)
LDPE	Poplar 60	110	5400	51
HDPE	Poplar 50	290	14,000	60
PP	Poplar 55	450	23,000	42
PP	Rice Husk60	400	30,300	47

Flex. Modulus (Kg/cm ²)	Impact StrengthNotched (J/m)
5400	51
14,000	60
23,000	42
30,300	47

Other Properties

- Density: Depending upon the formulation, density varies between 1.05-1.10 g/ml.
- Water Absorption: Immersion at Room Temperature – 0.25% max.
- Paintability: Needs pretreatment with a primer.
- Weatherability: Better than normal wood.
- Flammability: Can be made flame retardant.
- Termite Resistance: Can be made termite resistant.
- Handling /Machinability: All materials handle like wood with respect to screw holding, planing, and nailing (except PP based)

Effect of Heat/Temperatures/Water

Boiling Water Resistant
No Distortion at temperatures of 100 degrees Celcius.

Sample	Average Sample Size	Average Specifications
(after ½ hr in boiling water)		
Length	10 cm	10 cm
Width	3.054	3.06
Thickness	1.468	1.478
Weight	23.478 gms	23.682 gms

The percentage increase in dimensions is negligible.

Schematic Diagram

For Wood Composite Out of line Profile Extrusion

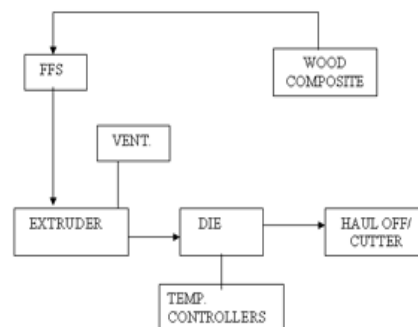

The above diagram indicates the major components of an offline extrusion system. The list is not a complete list and is indicative only. Actual setup will depend on the profile being extruded and the degree of automation desired.

Schematic diagram
Wood Composite Granules Manufacture
Or Inline Extrusion of Profiles

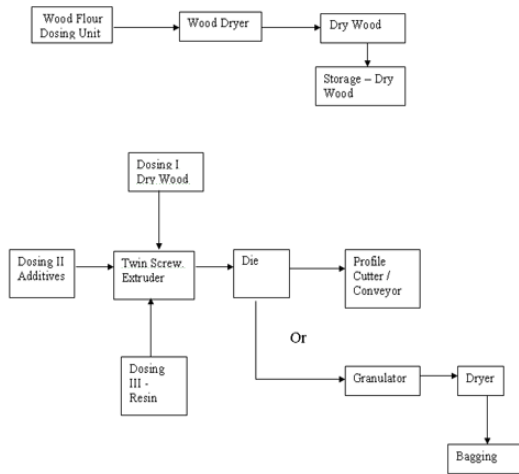

Or

The above diagram indicates the major components of an inline extrusion system. The list is not a complete list and is indicative only. Actual setup will depend on the profile being extruded and the degree of automation desired.

Costs of Raw Materials

Wood Flour (60%)	Rs. 4-8.00 per Kg
Base Resin (Balance)	Rs. 70.00 per Kg (virgin)
	Rs. 40.00 per Kg (reprocessed)
Additives (4 to 8 %)	Rs. 110.00 per Kg

Space Requirements

Assumptions

Production Capacity : 150 kgs/hr
No. of Days : 330
Total Hrs : 7920 hrs

Total Production : 1188 tonnes/year
Work on basis of Single Shift: 400 tonnes/year

Hence Space Required

Storage of Wood Flour : 2000 sq. ft. (3 months stock)
Storage of Profiles : 1000 sq. ft. (1.5 months stock)
Storage of Dried Wood Flour : Nil – To be fed inline
Basic Plant and Machinery* 2000 sq. ft.

This does not include space for

Final fabricated product.
All associated machinery in assembling and finishing windows/door profiles.

* Machinery included:

- Twin Screw Extruder 65 mm with TS side feeder, trough, cutter
- Wood Dryer
- Single Screw profile extruder with hopper dryer, die, cooling trough,
- Caterpillar and cutting bench
- Dryer for granules drying

Power Requirements

For assumed machinery in the section on space requirements;

The estimated total requirements of power will be about 225 kW.

Twin Screw Extruder : 90 kW
Single Screw Extruder : 22 kW
Dryers – Wood/Granule : 10 kW
Heaters : 100 kW

Additional Equipments for Profiles Assembly and Finishing will require extra power.

Allow for additional power for general lighting purposes.

What size Extruders?

Profile Size	Extrusion Speed	Extruder Size
1m x 4 cm thickness	1m/minute	1200 kgs/hr with 50% voids
1m x 4 cm thickness	½ m/minute	600 kgs/hr
1m x 2 cm		½ m/minute 300 kgs/hr

This material will compare very competitively with good quality wood.

Indirect savings include:

- Less wastage
- Less labour
- Exact profiles to suit requirements

Competitive Costs

PVC Window Profile

The estimated price of Elgi Building Products is Rs. 115/- meter. Finished window (including glass) is expected to be about Rs. 250/- per sq. ft. for a standard size of 4' x 4'.



MDF Boards

19 mm thick boards are Rs. 30/- per sq. ft. Wood composites will compete with this because of better functionality – such as water and abrasion resistance.

Teak

Average quality teak is Rs. 675 per cu. ft. Wood composites will compete with this in terms of labour cost savings. Material is saved because grooves etc. are formed during extrusion.

Door Frames – Standard Size

Costs from HUDCO – IITF 2002, Pragati Maidan, New Delhi

Deodar Frames	Rs. 1200
2 nd Grade Teak	Rs. 1450
Rubber Wood	Rs. 400
Jute/Polymer	Rs. 1100
Angle Iron	Rs. 450

Flush Doors – Standard Size

Jute/Polymer – Tipco	Rs. 2200
FRP Door	Rs. 1950
Plasopan Doors	Rs. 70 to Rs. 200 per sq.ft.

Basic Economics

Wood	60% @ 5.00	Rs. 3.00
PE	35% @ 70.00	Rs. 24.50
Additives	05% @ 110.00	Rs. 5.50
Total Cost		Rs. 33.00
Processing Costs/Other Expenses		Rs. 15.00
Total Costs		Rs. 48.00

Pluss Polymers Pvt. Ltd.

610 A, Udyog Vihar, Phase V, Gurgaon-122016 Haryana (INDIA).

Tel: +91-124-4309490 / 91 / 92. Fax: +91-124-4309493, Email: pluss@manasindia.com, Website: www.plusspolymers.com

The information given here is meant as a guide to determining suitability of our products for the stated applications. The products are intended for use in industrial applications. The users should test the materials before use and satisfy themselves in this regard. With regard to contents and suitability in the desired application. We guarantee that our products will meet our written specifications. Nothing herein shall constitute any other warranty expressed or implied. Recommendation herein may not be construed as freedom to infringe/operate under any third party patents. In the event of a proven claim, our liability is limited only to replacement of our material and in no case shall we be liable for special, incidental or consequential damages arising out of usage of our material.